

ENGLISH

Brief introduction

Thank you for purchasing the Olight S20-L2 Baton flashlight. Please read this manual carefully before using this product. Olight S20 BATOR got upgraded to 2013 edition, its LED changed to the latest in CREE XM-L2, both the structure and user interface were optimized, the performance were greatly raised.

Pack List

Flashlight x1, Spare O-Rings x2, lanyard x1, battery magazine x1, Silicone pad x1, Manual.

Product parts (See Figure 1)

Operational instruction (See Figure 2, 3)

Battery Installation: Insert the battery into the flashlight, refer to Figure 2, the battery positive towards light head.

Operate your light: There are adjustable brightness levels: moonlight-low-middle-high and strobe.

A) There are three ways to start up, under "OFF" status:

- 1) To quickly press side switch once to start up and output memorized brightness level.
- 2) To hold down side switch for 1 second to activate moonlight mode.
- 3) To quickly double press side switch to activate high mode.

B) Brightness level change :

- 1) If keep on holding down side switch, output changes in a circle of "moonlight-low-middle-high-low..."; while release to confirm the mode.
- 2) Quickly double press side switch to activate strobe (cannot be memorized), while normal press to quit and return to memorized mode.

C) Lock and unlock :

Lock operation: with the flashlight off, to hold down side switch for 1 second to activate moonlight mode, and then 3. press the side switch for another second without a stop to turn off output and the flashlight is in lock-out state.

Unlock operation: after locking out, just to hold down side switch for 1 second to unlock and activate moonlight mode.

Tips: side switch is invalid when the flashlight is in lock-out state, unless users are carrying out unlock operation.

Output VS Runtime (See Figure 4)

How to remove the magnet of S20-L2 Baton (See Figure 5)

Specifications

Material	Aluminum body with anti-scratching type III Hard Anodization
Dimension	L 106.0 mm, D23.0mm
Weight	52g(without battery)
LED	Cree XM-L2 LED
Battery	2 x CR123A or 1 X 18650
Output And Runtime	550 lumens /2h 120 lumens /9h 5 lumens /120h 0.5 lumens /600h
Special Mode	Strobe 10Hz
Peak Beam Intensity	3,500 cd
Beam Distance	118m
Waterproof	IPX 8
Impact Resistance	2m

Note: Testing with 2 piece of 1500mAh 3.0V CR123A

Warranty

Olight warrants its products to be free from defects in materials and workmanship. Within 30 days of receipt, any defective lights will be offered repair or replacement by the retailer where the product was purchased. Olight will repair or replace, at its option and without charge, any product or part which is found to be defective under normal use and service within 5 years counting from the date of purchasing with proof of purchase. Such repair or replacement shall be the purchaser's sole and exclusive remedy under this warranty. This warranty does not cover normal maintenance and service and does not apply to any products or parts which have been subject to modification, misuse, negligence, accident, improper maintenance or repair by anyone other than Olight. As to those exceed 5 years of the purchase date, Olight will still provide with warranty service. Labor is free but cost of parts will be charged. This warranty covers parts and labor only as specified above. Freight and transit costs are the responsibility of the user/owner, not the factory or dealer.

中文

产品简介

感谢您购买Olight LED手电筒，在使用前请仔细阅读说明书，本说明书适用于S20-L2 Baton。

Olight S20指挥官2013升级版，LED更新为最新的CREE XM-L2，并优化结构与操作界面，极大的提升了产品性能。

包装清单

手电x1, 备用O圈x2, 挂绳x1, 电池套x1, 硅胶垫x1, 说明书。

产品部件 (见Figure 1)

操作说明 (见Figure 2, 3)

电池安装:

按照Figure 2所示装入电池, 电池正极朝向手电头部。

使用手电:

手电具有月光、低、中、高四个亮度级别以及暴闪。

关机状态下, 3种方式开启手电:

- 1) 快速单按侧按键, 手电开启, 输出记忆的亮度;
- 2) 持续按住按键1秒, 输出月光亮度;
- 3) 快按两次按键, 输出高亮。

改变手电输出:

- 1) 若持续按住按键, 输出按月光 -> 低 -> 中 -> 高 -> 低... 顺序依次循环, 按键释放时, 输出选定亮度。
- 2) 快速双按侧按键输出暴闪 (不记忆), 在暴闪状态下常按退出暴闪返回记忆的亮度。

锁键与解锁:

上锁操作: 关机时按住按键1秒, 在开启月光后持续再按住1秒, 输出关闭, 进入锁键状态。

解锁操作: 持续按下按键1秒, 解锁并开启月光。

注意: 按键在上锁状态下, 不会响应用户操作, 除非是解锁操作。

运行曲线 (见Figure 4)

如何替换S20-L2 Baton尾盖的磁铁 (见Figure 5)

规格参数

材料	铝合金, 表面三级硬质氧化
尺寸	长106.0毫米, 直径23.0毫米
重量	52克(不带电池)
LED	CREE XM-L2 LED
电池	2 x CR123A or 1 X 18650
输出亮度及运行时间	550流明/2小时 120流明/9小时 5流明/120小时 0.5流明/25天
特殊模式	暴闪: 10Hz
中心光强度	3,500 cd
最大射程	118米
防水	IPX 8
抗冲击	2米

备注: 使用2节 1500mAh 3伏 CR123A锂电池测试

保修条款

细则说明:

1. 本细则适用于Olight品牌的手电及配件产品。凡通过正规渠道购买的Olight产品, 均享受本公司提供的免费保修或有限保修售后服务。

2. 任何产品或配件经过改装、不当使用或由非Olight产品提供的电池漏液导致产品无法使用, Olight将不承担其保修责任;

保修承诺:

1. 30天保换期: Olight手电产品自售出之日起30天内 (以购买发票或者其他有效购买单据上的日期为准), 在正常使用情况下, 出现产品质量问题, 客户可选择更换新品及配件, 或维修服务;
2. 5年免费保修期: Olight手电产品自售出之日起5年内 (以购买发票或者其他有效购买单据上的日期为准), 用户在正常使用情况下, 出现产品质量问题, 则享受免费维修服务;
3. 终身有限保修: 在超过5年免费保修时间外, Olight将提供有偿保修, 更换配件及运输费用由用户承担, 不另收取人工费用;
4. 电池质保: Olight为随产品提供或单独销售的可充电电池提供1年 (以购买发票或者其他有效购买单据上的日期为准) 质保;
5. 用户保修时凭Olight保修条款及购买有效单据与经销商联系, 由经销商对消费者提供服务, 我公司将对经销商提供服务支持;

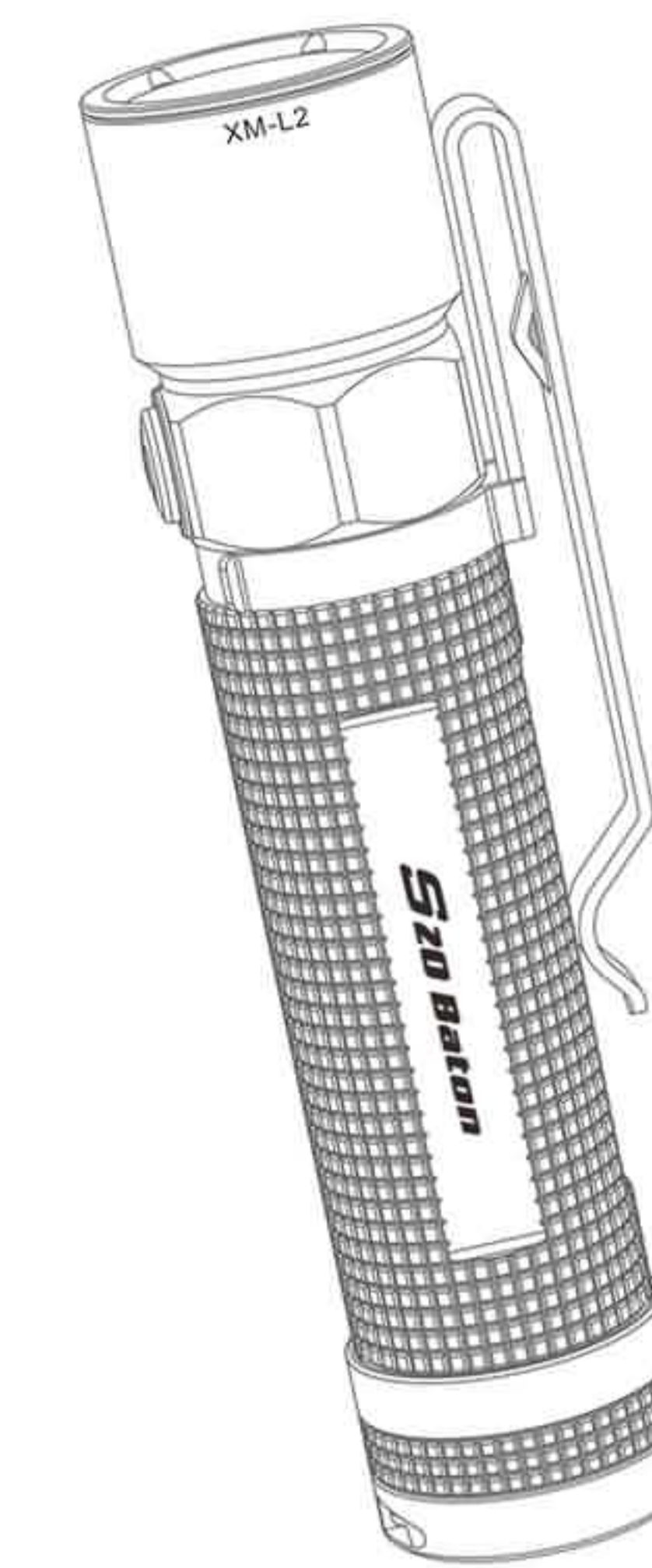

LED FLASHLIGHT
Model: S20-L2 Baton
CREE XM-L2 LED

EN User's manual

中文 用户手册



Olight Technology Co., Limited
Address: 2/F East, Building A, B3 Block,
Fuhai Industrial Park, Fuyong, Bao'an
District, Shenzhen, China 518103
Tel: +86-755-81452608/81452618
Fax: +86-755-81452508
E-mail: service@olightworld.com
www.olightworld.com

深圳市欧莱特科技有限公司
地址: 深圳市宝安区福永镇福海工业区
B3区栋二栋东
电话: 0755-81452608/81452618
传真: 0755-81452508
E-mail: service@olightworld.com
www.olightworld.com



Made in China

Figure 1 Product parts/产品部件

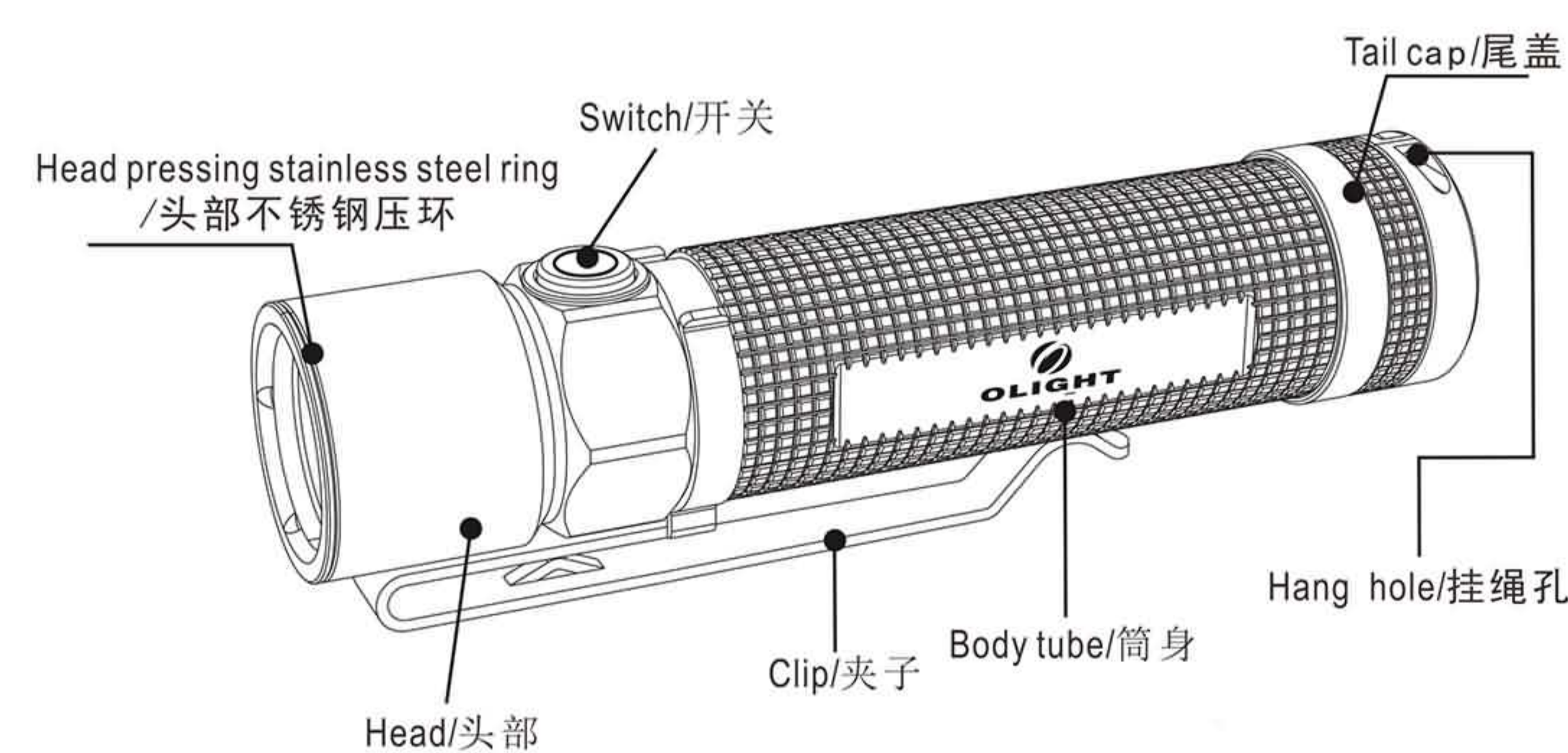

Figure 2 Battery installation/电池安装

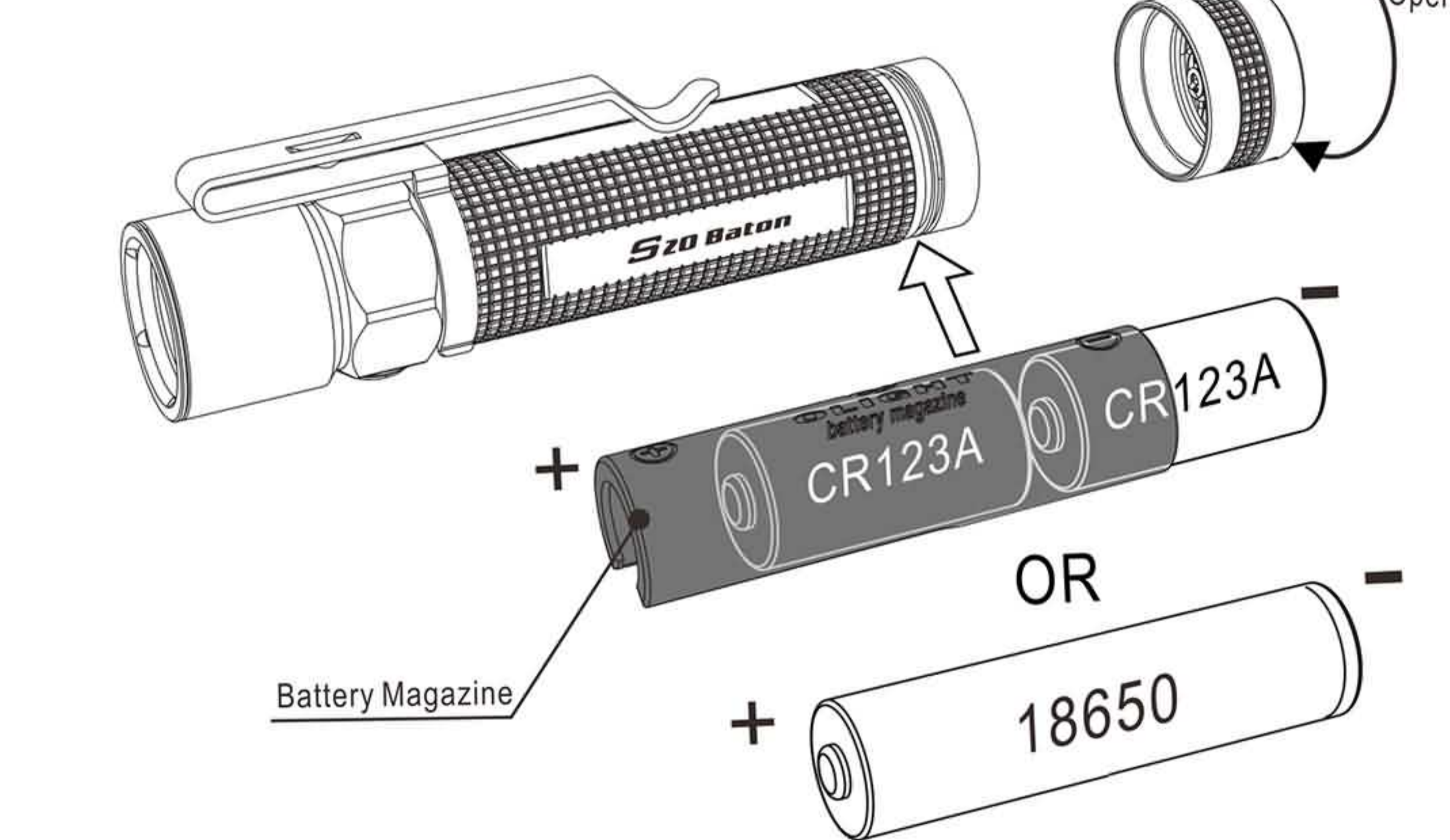

Figure 3 User interface / 用户操作界面

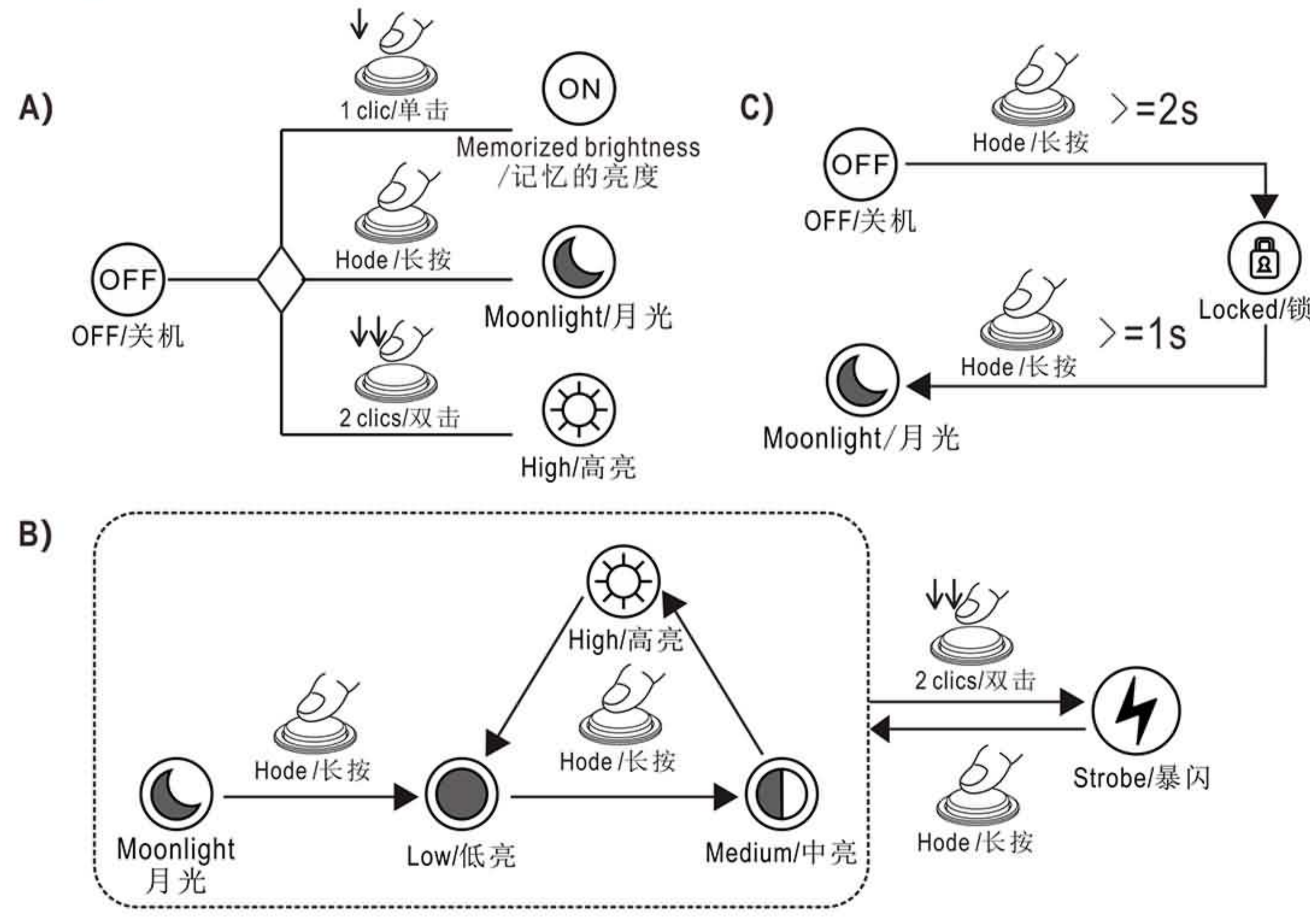

Figure 4 Output VS Runtime/运行曲线

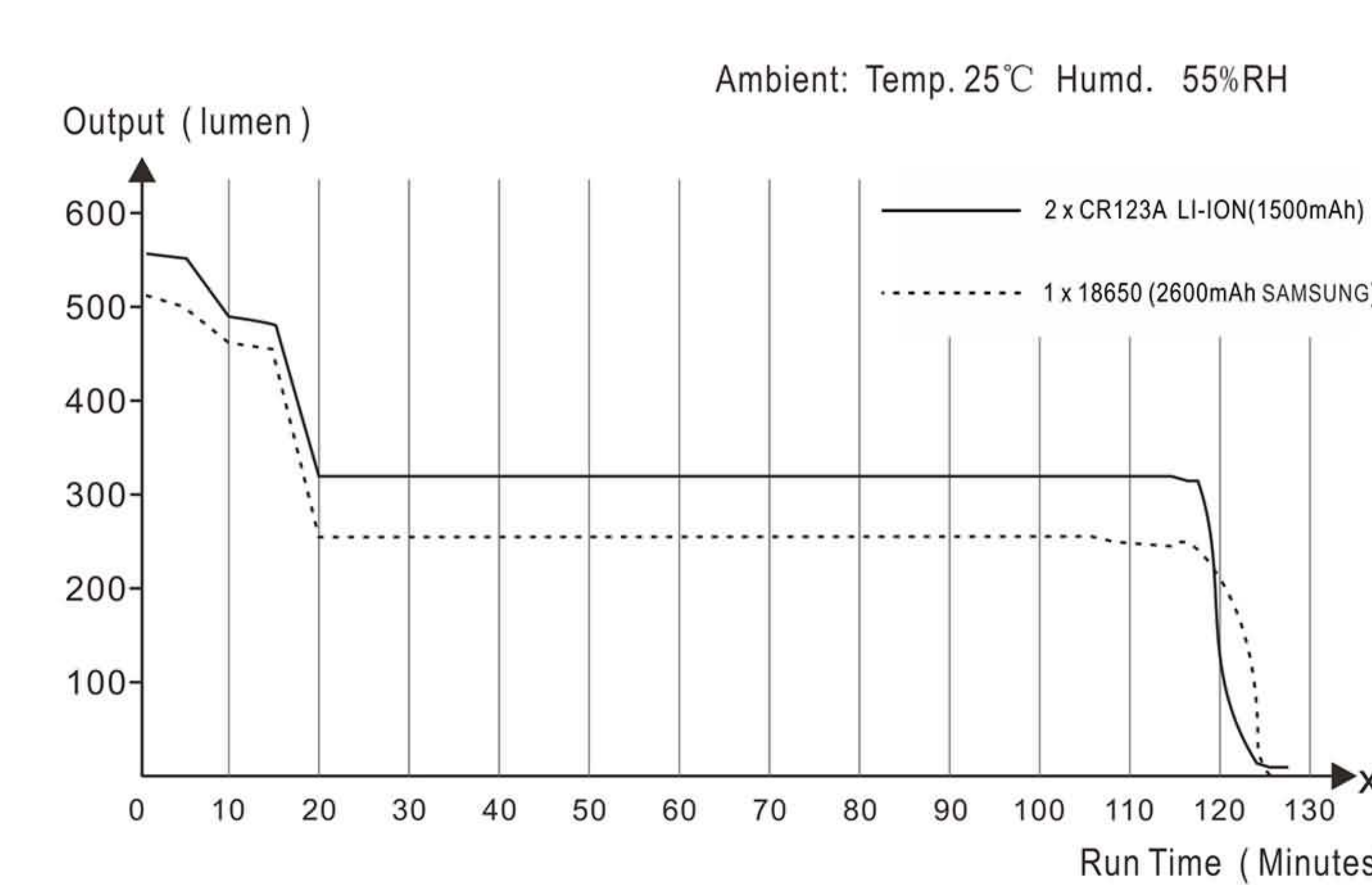
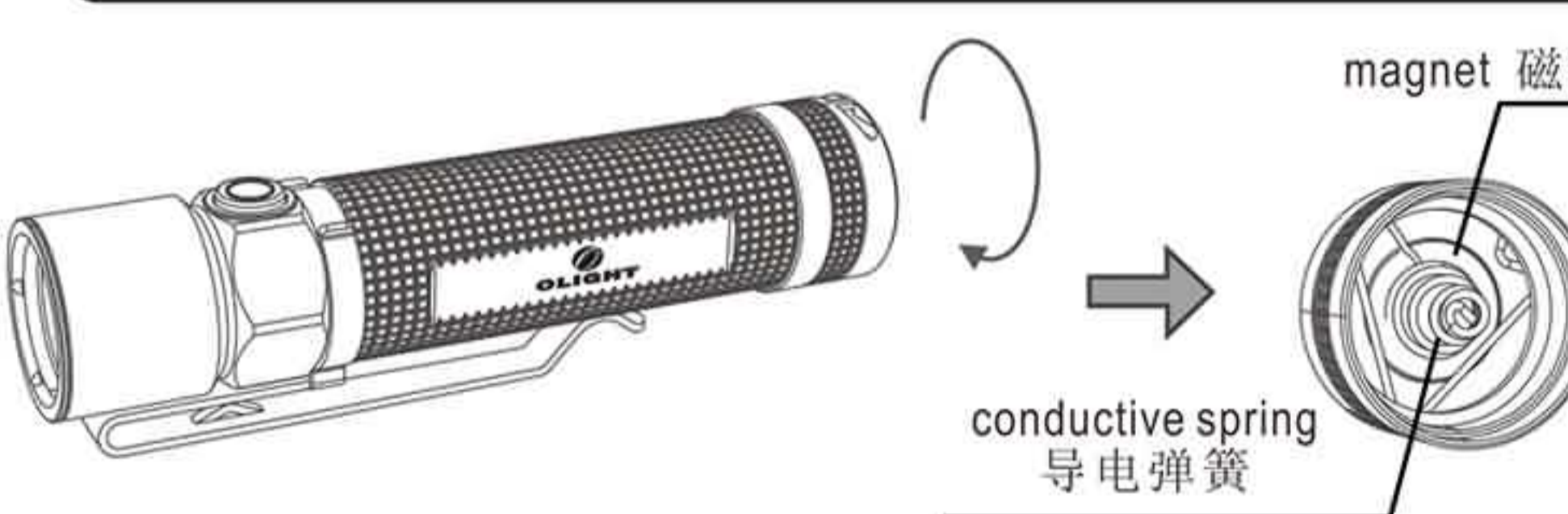

Figure 5 How to remove the magnet of S20-L2 Baton/如何替换S20-L2 Baton尾盖的磁铁

Required Tools: one tweezers / 准备工具: 一把镊子

1) Unscrew the tail cap / 旋开尾盖



Unscrew the tail cap, the conductive spring and inner magnet can be found. 旋开尾盖, 可以看见尾盖, 电极导电弹簧与内部的磁铁。

2) Take out the spring / 取出弹簧



Put the tips of the tweezers into the location as shown in left, then fold the tweezers by force so that the roots of conductive spring get away from the groove in tail cap, and take out the conductive spring. 镊子的两个尖端伸入如图所示的位置, 然后用力合拢镊子, 使弹簧根部脱离尾盖沟槽, 然后取出。

3) Take out the magnet / 取出磁铁

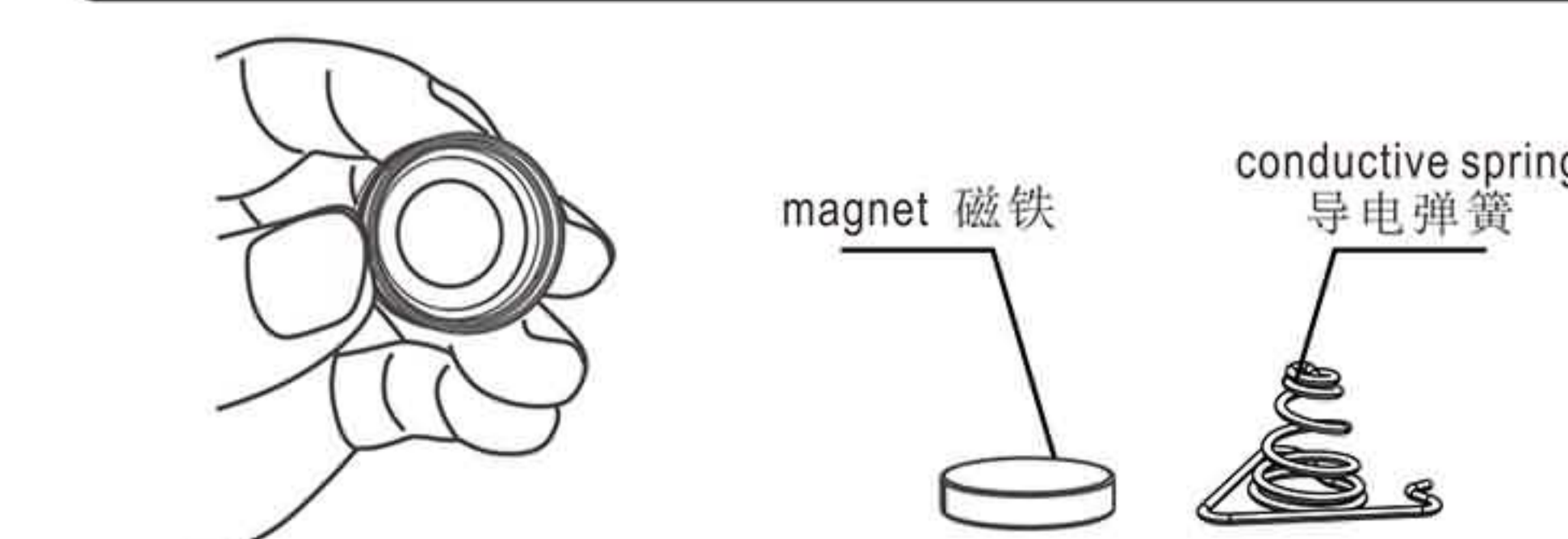

Once the conductive spring is taken out, the magnet will fall out from tail cap. 一旦导电弹簧取出, 磁铁将从尾盖里面掉出来。

4) Install silicone pad / 安装硅胶垫

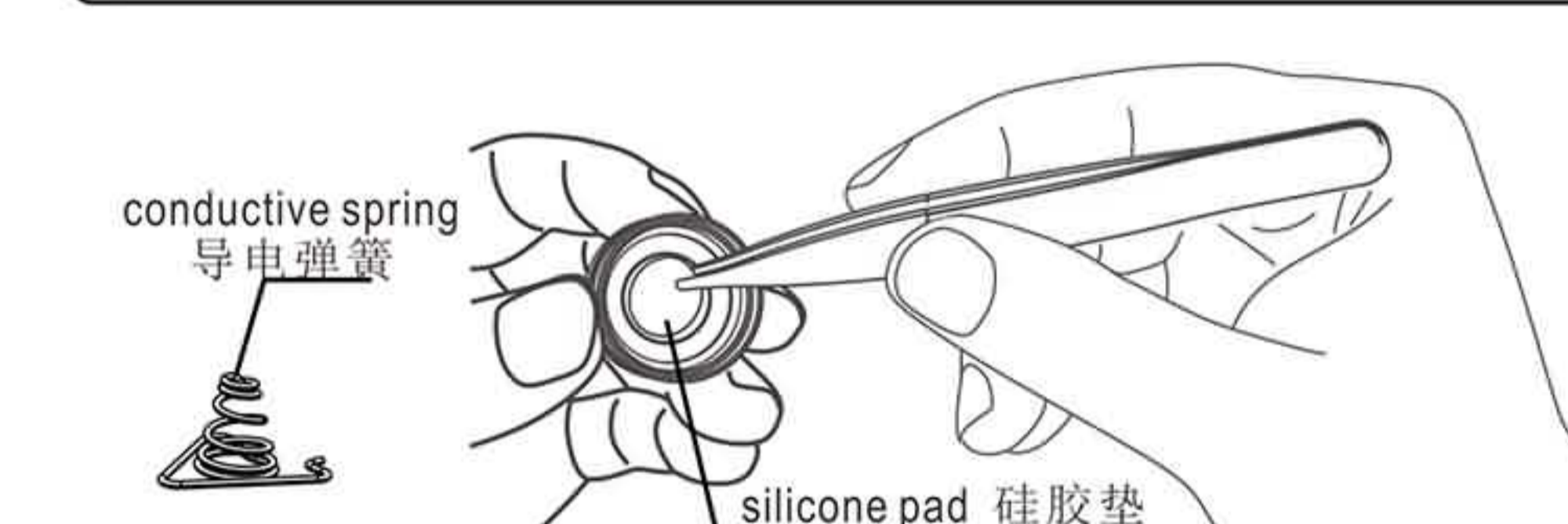

There is a black silicone pad with diameter 17mm, thickness 3mm in the package, find it out and fill this silicone pad into the location where the magnet was. 产品包装里面包含了一个直径17毫米, 厚度3毫米黑色的硅胶垫, 将此硅胶垫塞入尾盖部的原来磁铁的位置。

5) Install the conductive spring / 安装导电弹簧

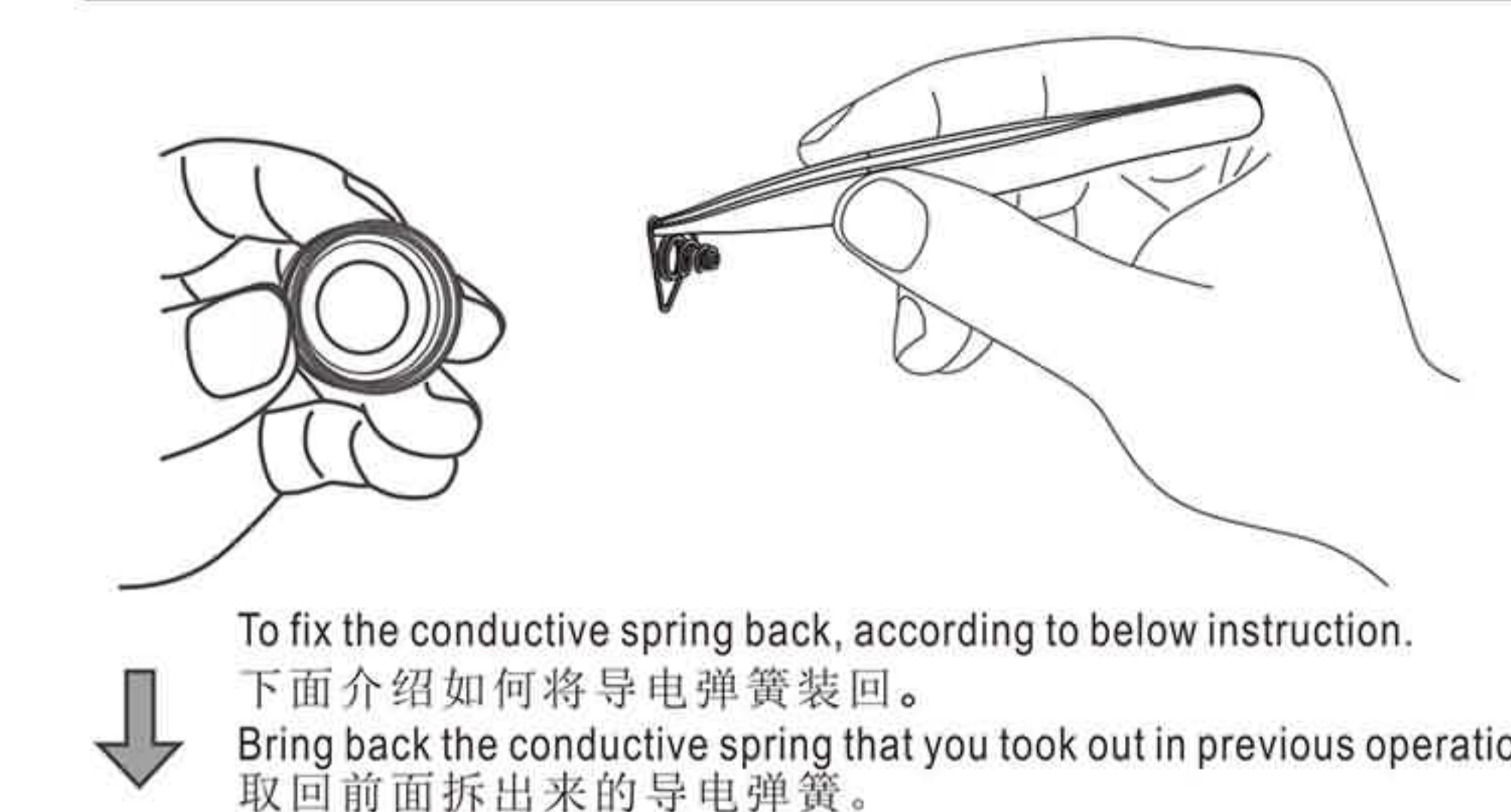

To fix the conductive spring back, according to below instruction. 下面介绍如何将导电弹簧装回。 取回前面拆出来的导电弹簧。

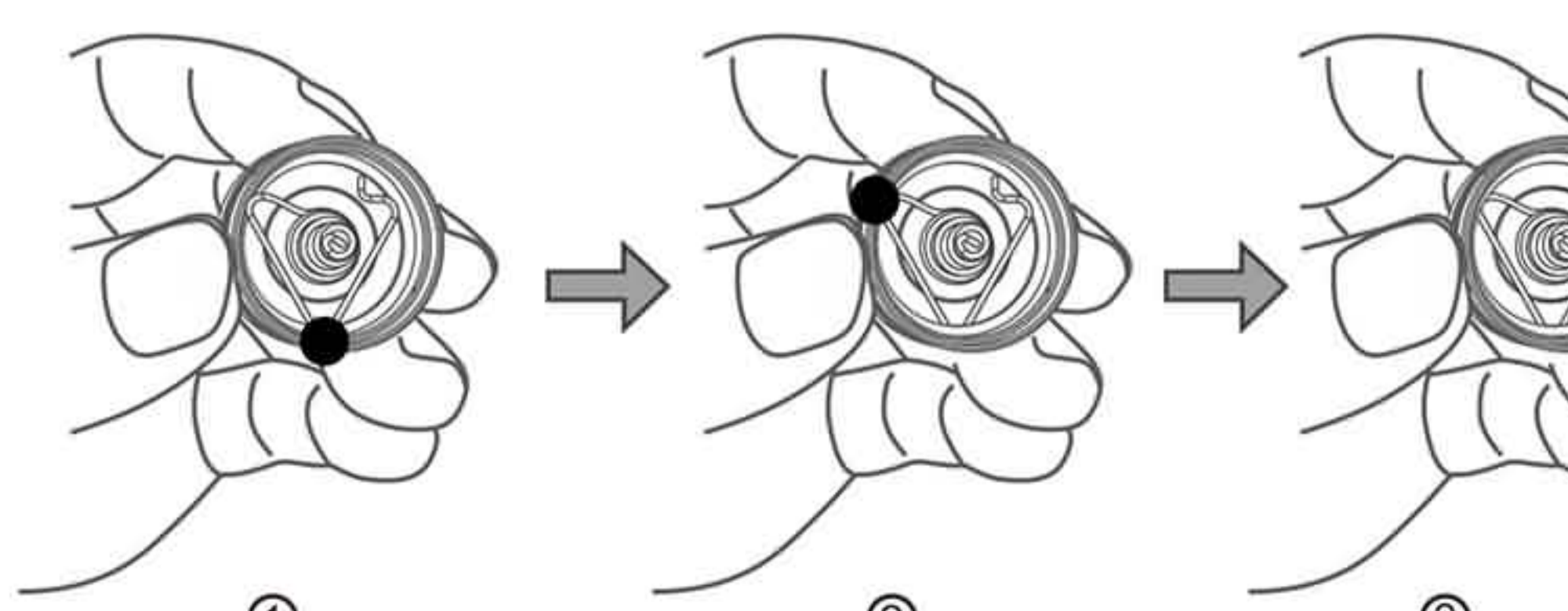

Firstly, insert this foot of the conductive spring into the groove of tail cap. 首先将此脚插入尾盖沟槽。 then next. 紧接着是下一个。 Finally, embed the third foot into the groove, so complete returning the conductive spring to tail cap, operation ends. 最后, 将第三支脚也嵌入到沟槽里, 完成将导电弹簧装回尾盖, 结束操作。